

A Pragmatic Approach to Build Conversation Protocols using Social Commitments

Roberto A. Flores
Laval University
Department of Informatics
Sainte-Foy, Quebec, Canada G1K 7P4
flores@damas.ift.ulaval.ca

Robert C. Kremer
University of Calgary
Department of Computer Science
Calgary, Alberta, Canada T2N 1N4
kremer@cpsc.ucalgary.ca

1. Introduction

We present a model to build conversation protocols aiming at the execution of actions. Our contention is that protocols can be explained as an orderly sequence of messages for adopting and discharging action-entailing social commitments. This model explicitly indicates the messages that are allowed (sequencing) and the agent that is expected to issue the next message (turn-taking) in all conversational states, thus defining state properties upon which the construction and verification of protocols can be based.

2. Negotiating Social Commitments

Social commitments [1] are engagements in which an agent is responsible relative to another agent for the performance of an action. In our model, the adoption and discharge of commitments is achieved using messages containing the following conversational tokens: *propose* (proposing to adopt or discharge commitments), *accept* (accepting to adopt or discharge commitments), *reject* (rejecting to adopt or discharge commitments), and *counter* (rejecting a proposal while putting forth another proposal instead).

We define an interaction protocol called the *protocol for proposals (pfp)* [2] that provides a flexible and unambiguous pattern of conversational sequencing and turn-taking for the mutual adoption and discharge of social commitments. The protocol starts with a proposal that can be replied (before the expiration of a deadline) with an acceptance, rejection or counterproposal. Either the speaker or addressee can reply to a proposal, but acceptances are only valid if issued by the addressee. While counterproposals are followed by either an acceptance, a rejection or another counterproposal, all other replies terminate the instance of the protocol. When a valid acceptance is issued, both agents simultaneously apply the proposed and accepted social commitment operations to their record of social commitments.

Although the negotiation of commitments is the central piece upon which our model is founded, it is nevertheless a vehicle to an end: that of giving rise to obligations to act.

By adopting social commitments, agents not only uptake the shared state of these commitments, but also uptake obligations to do the actions in which they are named as actors.

3. Building Conversation Protocols

Protocols are composed modularly based on actions and the roles that agents can play in these actions. An *action* can be either individual (i.e., an atomic action performed by one agent) or composite (i.e., a group of individual or composite actions). *Joint actions* are simplistically defined as composite actions with two or more performers. A *role* is a set of performances that an agent is assigned in joint actions. *Joint activities* are templates defining dependencies between joint actions and roles, and where protocols are defined.

Complex protocols involve several actions, some of which could be carried out consecutively or simultaneously, some of which could set the post-conditions (in terms of data and commitments) that fulfill the preconditions of subsequent ones. Rather than explicitly specifying the pre- and post-conditions of protocols, we let preconditions be set by the constraints of messages in roles; and post-conditions be set by the data resulting from actions, and the commitments remaining after *pfp* exchanges.

We followed this technique in our latest work [3], where we specified a Contract Net Protocol (CNP) activity as the union of three joint actions: offering to execute actions, evaluating proposed actions, and executing actions. These actions, which are shown in Figure 1 as actions *A*, *B* and *C*, defined independent agent roles. Two additional agent roles (a *bidder* and a *manager*) were defined by merging roles from each of these joint actions, e.g., the bidder was defined using the roles of the agent that offers to execute actions, the agent that requests the evaluation of actions, and the agent that executes actions. Messages in these new roles were refined with dependencies between the data used as input and output by each action, e.g., a proposal resulting from an offering action is the same as the input to an evaluating action. Lastly, we specified the order of actions in the activity by binding the messages of agents roles according to their

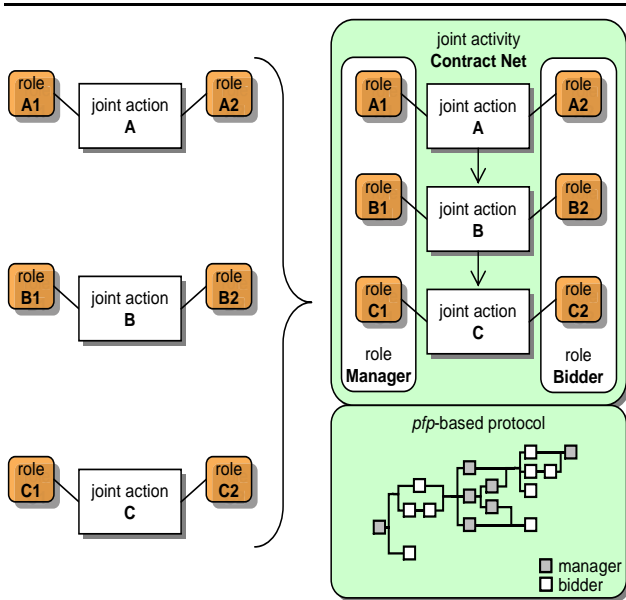

Figure 1. Overview of the CNP joint activity.

data constraints and to the *pfp*, e.g., a bidder could only propose to a manager to evaluate a bid if she has the commitment to produce a bid and if she is also proposing to discharge her commitment to produce one, which is a commitment that could only exist in the activity if she and the manager have previously negotiated its adoption.

We analyzed the flexibility of this protocol (in terms of the number of unique message sequences (or *runs*) it could support), and found that it affords much greater flexibility (without substantial overhead in terms of the number of subsequent messages) than comparable *ad hoc* interaction protocols. It is crucial to point out that protocols in our model would not be any different from any informal protocol if it was not for the strict dependencies between *pfp* messages and the states they establish while negotiating commitments. Readers interested in a formal account of the dynamics of conversations can refer to [2], where a segment of a *pfp* interaction is analyzed through logical proofs.

4. Related Work and Conclusions

Conversations and social commitments have been the subject of previous studies. On the one hand, some efforts have studied commitments in argumentation [5], which focus on the commitments that are implied in communicated propositions as the motivation behind the evolution of conversations. Similarly to our approach, other efforts (e.g., [4, 6]) have focused on the mechanics of conversations based on the operations that can be applied to advance the state of social commitments, which is a view independent of the intentional motives behind their advancement.

To conclude, the main contribution of this work is to demonstrate that conversation protocols can be composed in a modular manner through inferential principles supporting heterogeneity and flexibility in open environments. Our model supports heterogeneity by defining protocols using social commitment messages yielding obligations influencing action performance. By focusing on the properties of messages rather than on the implementation of actions, it allows designers to implement agents using their programming technique of choice. By featuring an inferential definition of sequencing and turn-taking, it allows protocols whose correctness could be verified at design time and then hard-coded in agents using a procedural language or programmed as inference rules in deliberative agents (whom then could verify compliance to the protocol at runtime). By supporting counterproposals it allows flexible protocols that sophisticated agents can use to exploit context-dependent circumstances, while also allowing interactions with less able agents that only follow message sequences leading directly to successful terminations (and whom may not pursue or immediately reject counterproposals). These principles also support agent autonomy by gradually reaching agreement rather than imposing the uptake of social commitments. Lastly, we support the modular composition of protocols by structuring them in terms of reusable, loosely coupled components such as messages, social commitments, actions, activities, roles and data.

5. Acknowledgments

We are thankful for the support received from the National Science and Engineering Research Council (NSERC) of Canada, and the Alberta Software Engineering Research Consortium (ASERC).

References

- [1] C. Castelfranchi. Commitments: From individual intentions to groups and organizations. *First ICMAS*, 1995.
- [2] R.A. Flores. *Modelling agent conversations for action*. Ph.D. thesis, Comp. Science, U. of Calgary, June, 2002.
- [3] R.A. Flores and R.C. Kremer. A principled modular approach to construct flexible conversation protocols. *17th Canadian AI Conference*, London, Canada, 2004.
- [4] N. Fornara and M. Colombetti. Defining interaction protocols using a commitment-based agent communication language. *AAMAS 2003*, Melbourne, Australia.
- [5] D.N. Walton and E.C.W. Krabbe. *Commitment in Dialogue*. State University of New York Press, 1995.
- [6] P. Yolum and M.P. Singh. Flexible protocol specification and execution: Applying event calculus planning using commitments. *AAMAS 2002*, Bologna, Italy.